



Reliable Horsepower 10.3L  
(GIP018103 and GIP0181031)

Specifications  
and  
General Service Manual

---

# Engine Mechanical – 10.3L

## Specifications

### Fastener Tightening Specifications

Application	Specification	
	Metric	English
Camshaft Position Sensor Bolt	14 N•m	10 lbs. ft.
Camshaft Retainer Bolt	12 N•m	9 lbs. ft.
Camshaft Sprocket Bolt	30 N•m	22 lbs. ft.
Connecting Rod Nut	85 N•m	63 lbs. ft.
Coolant Drain Hole Plug		
Left Front	60 N•m	44 lbs. ft.
Sides	20 N•m	15 lbs. ft.
Crankshaft Balancer Bolt	115 N•m	85 lbs. ft.
Crankshaft Bearing Cap Bolt	142 N•m	105 lbs. ft.
Crankshaft Position Sensor Bolt	14 N•m	10 lbs. ft.
Cylinder Head Bolt (In Sequence)		
First Pass	41 N•m	30 lbs. ft.
Second Pass	81 N•m	60 lbs. ft.
Third Pass	108 N•m	80 lbs. ft.
Cylinder Head Coolant Hole Plug	23 N•m	17 lbs. ft.
Exhaust Manifold		
Center Bolt	35 N•m	26 lbs. ft.
Nut	16 N•m	12 lbs. ft.
Stud	20 N•m	15 lbs. ft.
Exhaust Manifold Heat Shield		
Bolt	25 N•m	19 lbs. ft.
Nut	25 N•m	19 lbs. ft.
Flywheel Bolt	89 N•m	66 lbs. ft.
Front Cover Bolt	12 N•m	9 lbs. ft.
Ignition Coil Bolt	14 N•m	10 lbs. ft.
Intake Manifold Bolt (In Sequence)		
First Pass	20 N•m	15 lbs. ft.
Second Pass	41 N•m	30 lbs. ft.
Third Pass	41 N•m	30 lbs. ft.
MAP Sensor Bolt	12 N•m	106 lbs. in.
Oil Cooler Hose Fittings	23 N•m	17 lbs. ft.
Oil Filter	38 N•m	12 lbs. ft.
Oil Filter Fitting	66 N•m	49 lbs. ft.
Oil Pan Bolt	25 N•m	18 lbs. ft.
Oil Pan Drain Plug	28 N•m	21 lbs. ft.
Oil Pump Bolt	88 N•m	65 lbs. ft.
Oil Pump Cover Bolt	12 N•m	106 lbs. in.
Oil Pump Drive Bolt	24 N•m	18 lbs. ft.
Spark Plug	30 N•m	22 lbs. ft.
Thermostat Housing Bolt	30 N•m	22 lbs. ft.
Valve Lifter Guide Retainer Bolt	24 N•m	18 lbs. ft.

Valve Rocker Arm Cover Bolt	14 N•m	10 lbs. ft.
Valve Rocker Arm Stud	47 N•m	35 lbs. ft
Water Pump Bolt	42 N•m	31 lbs. ft
Water Pump Pulley Bolt	25 N•m	19 lbs. ft

### Engine Mechanical Specifications

Application	Specification	
	Metric	English
<b>General Data</b>		
Engine Type	V-8	
Displacement	10.3L	632 CID
Bore	116.94 mm	4.600 in
Stroke	120.65 mm	4.750 in
Compression Ratio	10.5:1	
Firing Order	1-8-7-2-6-5-4-3	
Spark Plug Gap	.76 mm	0.030 in
<b>Cylinder Head</b>		
Surface Flatness	0.050 mm	0.002 in
<b>Exhaust Manifold</b>		
Surface Flatness	0.254 mm	0.010 in
<b>Lubrication System</b>		
Oil Capacity without Filter Change	See install guide	See install guide
Oil Pressure (Minimum)	103 kPa @ 1,000 RPM	15 psi @ 1,000 RPM
Oil Pump Type	Gear Driven	
<b>Cylinder Bore</b>		
Diameter – Production	116.840-116.853 mm	4.6000-4.6005 in
Diameter - Service	116.843-116.881 mm	4.6001-4.6016 in
Out-of-Round Production (Maximum Minus Minimum Bore Diameter)	0.0180 mm (Maximum)	0.0007 in (Maximum)
Out-of-Round Service (Maximum Minus Minimum Bore Diameter)	0.050 mm (Maximum)	0.002 IN (Maximum)
Taper Production	0.0180 mm (Maximum)	0.0007 in (Maximum)
Taper Service - Thrust Axis	0.050 mm (Maximum)	0.002 in (Maximum)
Taper Service - Pin Axis	0.050 mm (Maximum)	0.002 in (Maximum)
<b>Engine Block (Production Specifications)</b>		
Main Bearing Bore Diameter	74.587-74.613 mm	2.9365-2.9375 in
Lifter Bore Diameter	21.417-21.443 mm	0.843-0.844 in
Deck Height from Crankshaft Bore	259.081 +/- .127 mm	10.200 +/- .005 in
Head Deck Surface Flatness (entire face)	0.100 mm	0.004 in
Head Deck Surface Flatness within 150 mm (6 in)	0.050 mm	0.002 in
<b>Piston</b>		
Piston Diameter (Coated Piston)	Not Measurable	Not Measurable
Clearance Production	Interference Fit (Coated Piston)	Interference Fit (Coated Piston)
<b>Piston Ring Compression</b>		
Top Groove Clearance	0.031-0.074 mm	0.0012-0.0029 in
Second Groove Clearance	0.031-0.074 mm	0.0012-0.0029 in
Top Ring Production Gap	0.762-0.813 mm	.030-.032 in
Top Ring Service Limit Gap	0.813-0.864 mm	.034-.036 in
Second Ring Production Gap	0.813-0.864 mm	.032-.034 in
Second Ring Service Limit Gap	0.864-0.914 mm	.036-.038 in
<b>Piston Ring Oil Control</b>		
Ring Groove Clearance	0.051-0.114 mm	0.002-0.0045 in
Production Gap	0.635-0.686 mm	.025-.027 in
Service Limit Gap	0.373-1.138 mm	.029-.031 in
<b>Piston Pin</b>		
Diameter	25.131-25.144 mm	.9894-.9899 in

Fit in Connecting Rod	0.015-0.053 mm Interference	0.0006-0.0021 in Interference
<b>Crankshaft</b>		
Crankshaft Main Journal Runout - Production	0.0380 mm (Maximum)	0.0015 in (Maximum)
Crankshaft Main Journal Runout - Service	0.0510 mm (Maximum)	0.0020 in (Maximum)
Crankshaft Journal Diameter #1, #2, #3, #4	69.799-69.825 mm	2.7480-2.7490 in
Crankshaft Journal Diameter #5	69.782-69.807 mm	2.7473-2.7483 in
Crankshaft Journal Taper Production	0.0102 mm (Maximum)	0.0004 in (Maximum)
Crankshaft Journal Taper Service Limit	-	-
Crankshaft Journal Out-of-Round Production	0.0102 mm (Maximum)	0.0004 in (Maximum)
Crankshaft Journal Out-of-Round Service Limit	-	-
Crankshaft Bearing Clearance #1, #2, #3, #4 Production	0.022-0.052 mm	0.0008-0.0020 in
Crankshaft Bearing Clearance #5 Production	0.035-0.067 mm	0.0014-0.0026 in
Crankshaft Bearing Clearance #1, #2, #3, #4 Service Limit	0.022-0.089 mm	0.0008-0.0035 in
Crankshaft Bearing Clearance #5 Service Limit	0.035-0.102 mm	0.0014-0.0040 in
Crankshaft End Play	0.127-0.279 mm	0.0050-0.0110 in
Crankpin Diameter	55.855-55.880 mm	2.1990-2.200"
Crankpin Taper Production	0.0102 mm (Maximum)	0.0004 in (Maximum)
Crankpin Out-of-Round Production	0.0102 mm (Maximum)	0.0004 in (Maximum)
Rod Bearing Clearance Production	0.021-0.064 mm	0.0008-0.0025 in
Rod Bearing Clearance Service Limit	0.021-0.081 mm	0.0008-0.0032 in
Connecting Rod Side Clearance	0.384-0.686 mm	0.0151-0.0270 in
<b>Camshaft</b>		
Camshaft Runout - Production	0.051 mm (Maximum)	0.003 in (Maximum)
Camshaft Runout - Service	0.076 mm (Maximum)	0.002 in (Maximum)
Lobe Lift Intake	7.645 mm	.301 in
Lobe Lift Exhaust	7.645 mm	.301 in
Journal Diameter	49.472-49.522 mm	1.9477-1.9479 in
Camshaft Bearing Inside Diameter	49.5480-49.5730 mm	1.9507-1.9517 in
<b>Valve System</b>		
Lifter	Hydraulic, Roller Followers	
Rocker Arm Ratio	1.70:1	
Valve Lash Intake	Net Lash	
Valve Lash Exhaust	Net Lash	
Face Angle (Intake/Exhaust)	45 degrees	
Seat Angle (Intake/Exhaust)	45 degrees	
Seat Runout (Intake/Exhaust)	0.050 mm (Maximum)	0.002 in (Maximum)
Seat Width Intake	0.800-1.200 mm	0.030-0.060 in
Seat Width Exhaust	1.651-2.159 mm	0.060-0.095
Stem Clearance Production Intake	0.025-0.0740 mm	0.0010-0.0029 in
Stem Clearance Production Exhaust	0.030-0.079 mm	0.0012-0.0031 in
Valve Spring Pressure Closed	115-129 N@ 44.831 mm	85-95lb@ 1.765"
Valve Spring Pressure Open	278 N@ 33.477 mm	205lb@ 1.318"
Valve Spring Installed Height	44.704-44.958 mm	1.760-1.770"
Valve Spring Free Length	56.185mm	2.212 in
Valve Head Diameter Intake	52.578mm	2.070in
Valve Head Diameter Exhaust	43.69 mm	1.72 in
Valve Stem Diameter Intake	9.436-9.454 mm	0.3715-0.3722 in
Valve Stem Diameter Exhaust	9.423-9.441 mm	0.3710-.3717 in

# Diagnostic Information and Procedures

## Base Engine Misfire Diagnosis

Checks	Action
	<p>Engine Performance diagnosis procedures are covered in Engine Controls and should be consulted for diagnosis of any Drivability, Emissions or Malfunctioning Indicator Lamp (MIL) concerns.</p> <p>The following diagnosis covers common concerns and possible causes.</p> <p>When the proper diagnosis is made, the concern should be corrected by adjustment, repair or replacement as required. Refer to the appropriate section of the service manual for each specific procedure.</p> <p>This diagnostic table will assist in engine misfire diagnosis due to a mechanical concern such as a faulty engine camshaft, worn or damaged bearings or bent valve pushrod.</p> <p>This table will not isolate a component failure that may cause a misfire.</p> <p>The Powertrain On-Board Diagnostic System checks must be performed first.</p> <p>When using this table to make a Base Engine Misfire diagnosis, begin with the preliminary information below and then proceed to the specific category.</p>
Preliminary	<ol style="list-style-type: none"> <li>1. Perform a visual inspection of the following: <ul style="list-style-type: none"> <li>A loose or improperly installed engine flywheel or crankshaft balancer</li> <li>Worn, damaged or misaligned accessory drive system components</li> </ul> </li> <li>2. Listen to the engine for any abnormal internal engine noises.</li> <li>3. Inspect the engine for acceptable oil pressure.</li> <li>4. Verify if the engine has excessive oil consumption.</li> <li>5. Verify if the engine has excessive coolant consumption.</li> <li>6. Perform a compression test on the engine.</li> </ol>
Intake Manifold Leaks	<p>An intake manifold that has a vacuum leak may cause a misfire.</p> <p>Inspect for the following:</p> <ul style="list-style-type: none"> <li>Improperly installed or damaged vacuum hoses</li> <li>Faulty or improperly installed lower intake manifold and/or gaskets</li> <li>Cracked or damaged lower intake manifold</li> <li>Improperly installed MAP sensor</li> <li>The sealing grommet of the MAP sensor should not be torn or damaged</li> <li>Improperly installed throttle body or damaged gasket</li> <li>Warped intake manifold</li> <li>Warped or damaged cylinder head sealing surface</li> </ul>
Coolant Consumption	<p>Coolant consumption may or may not cause the engine to overheat.</p> <p>Inspect for the following:</p> <ul style="list-style-type: none"> <li>External coolant leaks</li> <li>Faulty cylinder head gasket</li> <li>Warped cylinder head</li> <li>Cracked cylinder head</li> <li>Damaged engine block</li> </ul>
Oil Consumption	<p>Oil consumption may or may not cause the engine to misfire.</p> <ol style="list-style-type: none"> <li>1. Remove the spark plugs and inspect for oil fouled spark plug.</li> <li>2. Perform a cylinder compression test.</li> <li>3. If the compression test indicates worn valves or valve guides, inspect the following: <ul style="list-style-type: none"> <li>Worn, brittle or improperly installed valve stem oil seals</li> <li>Worn valve guides</li> <li>Worn valve stems</li> <li>Worn or burnt valves or valve seats</li> </ul> </li> <li>4. If the compression test indicates worn or damaged piston rings, inspect the following: <ul style="list-style-type: none"> <li>Broken or improperly seated piston rings</li> <li>Excessive piston ring end gap</li> <li>Excessive cylinder bore wear or taper</li> <li>Cylinder damage</li> <li>Piston damage</li> </ul> </li> </ol>

## Base Engine Misfire Diagnosis (cont'd)

Checks	Action
Abnormal Internal Engine Noises	<ol style="list-style-type: none"> <li>1. Start the engine and determine if the noise is timed to the engine camshaft speed or the crankshaft speed.</li> <li>2. Using a timing light, two knocks per flash is the crankshaft speed and one knock per flash is the engine camshaft speed.</li> <li>3. If the noise is timed to the engine camshaft speed, inspect the following: <ul style="list-style-type: none"> <li>Missing or loose valve train components</li> <li>Worn or loose valve rocker arms</li> <li>Worn or bent valve pushrods</li> <li>Faulty valve springs</li> <li>Bent or burnt valves</li> <li>Worn engine camshaft lobes</li> <li>Worn or damaged camshaft timing chain and/or sprockets</li> </ul> <p><b>Important:</b> A slight COLD knock or piston slapping noise could be considered normal if not present after the engine has reached normal operating temperatures.</p> <ul style="list-style-type: none"> <li>If the knock is timed to the crankshaft speed, inspect the following: <ul style="list-style-type: none"> <li>Worn crankshaft or connecting rod bearings</li> <li>Piston or cylinder damage</li> <li>Worn piston or piston pin</li> <li>Faulty connecting rod</li> <li>Excessive carbon build-up on the top of the piston</li> </ul> </li> </ul> </li> </ol>
No Abnormal Internal Engine Noise	<ol style="list-style-type: none"> <li>1. Inspect for a worn or improperly installed camshaft timing chain and/or sprockets.</li> <li>2. Remove the valve rocker arm cover on the side of the engine with the cylinder that is misfiring.</li> <li>3. Inspect for the following: <ul style="list-style-type: none"> <li>Loose valve rocker arm studs</li> <li>Bent valve push rods</li> <li>Faulty valve springs</li> <li>Faulty valve lifters (bleeding down)</li> <li>Worn or improperly seated valves</li> <li>Worn engine camshaft lobes</li> </ul> </li> </ol>

### Engine Compression Test

1. Disconnect ignition wires from ECM
2. Remove all the spark plugs.
3. Block the throttle plate wide open.
4. Charge the battery if the battery is not fully charged.
5. Start with the compression gauge at zero. Then crank the engine through four compression strokes (four puffs).
6. Make the compression check the same for each cylinder. Record the reading.  
The minimum compression in any one cylinder should not be less than 70 percent of the highest cylinder.
7. If some cylinders have low compression, inject approximately 15 ml (one tablespoon) of engine oil into the combustion chamber through the spark plug hole.
  - Normal - Compression builds up quickly and evenly to the specified compression for each cylinder.
  - Piston Rings Leaking - Compression is low on the first stroke. Then compression builds up - with the following strokes but does not reach normal. Compression improves considerably when you add oil.
  - Valves Leaking - Compression is low on the first stroke. Compression usually does not build up on the following strokes. Compression does not improve much when you add oil.
  - If two adjacent cylinders have lower than normal compression, and injecting oil into the cylinders does not increase the compression, the cause may be a head gasket leaking between the two cylinders.
8. Install the removed parts.
9. Connect the disconnected components.

## Engine Noise Diagnosis

Symptoms	Cause
<p>When diagnosing engine noise complaints, use the following steps to isolate the source of the engine noise:</p> <ul style="list-style-type: none"> <li>- Determine the type of noise</li> <li>For example, is the noise a light rattle/tapping or a low rumble/knocking?</li> <li>- The exact operating condition under which the noise exists</li> <li>Note factors such as ambient temperature, the amount of engine warm-up time, the engine temperature, the engine RPM and other specifics.</li> <li>- At what rate the noise occurs, and at what location on the engine</li> </ul> <p>Engine noises are generally synchronized to either engine speed (crankshaft, engine flywheel, connecting rods, crankshaft balancer or pistons and related components) or one-half engine speed (valve train noise such as valve rocker arms, valve lifters and camshaft timing chain). Determine the rate at which the noise is occurring.</p> <ul style="list-style-type: none"> <li>- Compare the engine sounds to other engines, and make sure you are not trying to correct a normal condition.</li> </ul>	
Noise on Start-Up but Only Lasts a Few seconds	<p>Improper oil viscosity. Install the recommended oil viscosity for the expected temperatures.</p> <p>Worn or dirty valve lifters</p> <p>Excessive piston-to-cylinder bore clearance</p> <p>Excessive piston pin-to-bore clearance</p> <p>Excessive crankshaft bearing clearance</p>
Knocks Cold and Continues for 1 to 2 Minutes	<p>Loose or broken crankshaft balancer or accessory drive components</p> <p>Excessive piston-to-bore clearance</p> <p>A cold piston knock which appears in 1.5 minutes should be considered acceptable.</p> <p>A cold engine knock usually disappears when the specific cylinders secondary ignition circuit is grounded out.</p>
Intermittent Noise on Idle, Disappearing When Engine Speed is Increased	<p>Improper oil viscosity. Install the recommended oil viscosity for the expected temperatures.</p> <p>Lower than specified oil pressure</p> <p>Install an oil pressure gauge and measure the engine oil pressure.</p> <p>Dirty or worn valve lifter</p>
Valve Train Noise (Rattle/Tapping)	<p>The following conditions may cause valve train noise:</p> <p>Lower than specified oil pressure</p> <p>Worn or faulty oil pump</p> <p>Loose oil pump-to-engine block bolt</p> <p>Loose valve rocker arm attachments</p> <p>Worn valve rocker arms and/or valve pushrods</p> <p>Broken valve spring</p> <p>Sticking valves</p> <p>Worn, dirty or faulty valve lifters</p> <p>Worn engine camshaft lobes</p> <p>Worn valve guides or valve stems</p> <p>Bent, broken or damaged timing chain sprocket teeth</p>
Knocks Hot at Idle (Rumble/Knocking)	<p>The following conditions may cause a knocking noise:</p> <p>Malfunctioning accessory drive system components</p> <p>Loose or broken crankshaft balancer</p> <p>Detonation or spark knock</p> <p>Check for proper operation of the cooling, knock and ignition control components.</p> <p>Excessive connecting rod bearing clearance</p> <p>Excessive piston pin-to-bore clearance</p> <p>Bent connecting rod</p> <p>Excessive crankshaft bearing clearance</p> <p>Loose torque converter bolts (if equipped)</p> <p>Cracked or damaged engine flywheel</p> <p>Exhaust leak at the exhaust manifold</p> <p>Combustion chamber deposits</p>
Exhaust System Noise and/or Leakage	<p>Exhaust system noise and/or leakage may be caused by the following conditions:</p> <p>Improperly installed or misaligned exhaust system components</p> <p>A cracked or broken exhaust manifold</p> <p>Damaged or worn exhaust manifold gaskets and/or seals</p> <p>Burnt or rusted out exhaust system components</p> <p>Broken or loose exhaust clamps and/or brackets</p>

# Valve Train Diagnosis

## General Information

Symptoms	Cause
<p>A light tapping noise at 1/2 engine speed, or any varying frequency, may indicate a valve train problem. Tapping noises will typically increase with increased engine speed. Before attempting to diagnose a valve train noise, check for the proper engine oil level and then allow the engine to obtain normal operating temperature. Following this procedure will bring all engine components to a normal state of expansion. Operate the engine at various speeds and listen for any abnormal engine noise.</p>	
Valve Train Noise	<ul style="list-style-type: none"> <li>Low engine oil pressure</li> <li>A worn or faulty oil pump</li> <li>A loose or plugged oil pump screen</li> <li>Loose valve rocker arm attachments (causing excessive valve lash)</li> <li>A worn or damaged valve rocker arm ball</li> <li>A worn valve rocker arm and/or valve pushrod</li> <li>A broken valve spring</li> <li>Sticking valves</li> <li>Valve lifters worn, dirty or faulty</li> <li>A broken valve lifter guide</li> <li>Engine camshaft lobes worn</li> <li>Worn valve guides or valve stems</li> <li>Bent valve pushrods</li> <li>Excessive free play in the camshaft timing chain</li> <li>Bent, broken or damaged camshaft sprocket teeth</li> </ul>

## Diagnostic Table

Step	Action	Value(s)	Yes	No
DEFINITION: A light tapping noise at 1/2 engine speed, or any varying frequency.				
1	Is there valve train noise?	—	Go to Step 2	System OK
2	Check for a high engine oil level. An engine with the engine oil level above the FULL mark on the oil level indicator allows the crankshaft counterweights to churn the engine oil into foam. When the foamy engine oil is pumped into the valve lifters, the valve lifters become noisy. A solid column of engine oil ensures proper valve lifter operation. Is the engine oil level too high?	—	Go to Step 3	Go to Step 4
3	Drain the engine oil to the proper level. Is the tapping noise gone?	—	System OK	Go to Step 6
4	Check for a low engine oil level. An engine with the engine oil level below the ADD mark on the oil level indicator may allow the oil pump to pump air at high engine RPM. Is the engine oil level below the ADD mark on the oil level indicator?	—	Go to Step 5	Go to Step 6
5	Add the engine oil as required. Is the tapping noise gone?	—	System OK	Go to Step 6
6	Check for the proper engine oil pressure. Refer to Engine Mechanical Specifications and Oil Pressure Diagnosis and Testing. Is the engine oil pressure within specifications?	—	Go to Step 11	Go to Step 7



### Diagnostic Table (cont'd)

Step	Action	Value(s)	Yes	No
7	Check the oil pump screen for damage or a loose fit to the oil pump. Is the oil pump screen loose or is the oil pump screen damaged?	—	Go to Step 8	Go to Step 9
8	Repair as required. Is the tapping noise gone?	—	System OK	Go to Step 9
9	Check for a damaged oil pump or loose bolts. Refer to Oil Pump Clean and Inspect. Is the oil pump damaged or are the bolts loose?	—	Go to Step 10	Go to Step 11
10	Repair as required. Is the tapping noise gone?	—	System OK	Go to Step 11
11	Remove and inspect the valve lifters, the valve rocker arms and the valve pushrods. Refer to Valve Rocker Arm and Pushrods Clean and Inspect and Valve Lifters and Guides Clean and Inspect. Are the components worn or damaged?	—	Go to Step 12	Go to Step 13
12	Replace the components as required. Is the tapping noise gone?	—	System OK	Go to Step 13
13	Perform an engine camshaft lobe lift test. Refer to Camshaft and Bearings Clean and Inspect. Are the engine camshaft lobes within specifications?	—	Go to Step 15	Go to Step 14
14	Replace the engine camshaft and valve lifters. Is the tapping noise gone?	—	System OK	Go to Step 13
15	Remove the engine front cover and inspect the camshaft timing chain and sprockets for excessive wear or damage. Refer to Timing Chain and Sprockets Clean and Inspect. Are the components worn or damaged?	—	Go to Step 17	Go to Step 16
16	Replace the components as required. Is the tapping noise gone?	—	System OK	Go to Step 17
17	Perform a complete disassembly of the engine and inspect all components. Are the components worn or damaged?	—	System OK	Go to Step 11
18	Replace the components as required. Did you complete the worn or damaged component replacement?	—	System OK	—

---

## Oil Usage Diagnosis

Oil consumption can be affected by many conditions, including but not limited to the following factors:

- External oil leaks.
- Incorrect oil level, improper reading of oil level indicator, and/or malfunctioning oil level maintainer.
- Improper oil viscosity. Use recommended SAE type and viscosity. (See Owner's Manual)
- Continuous high speed operation and/or severe usage.
- Crankcase ventilation system restrictions or malfunctioning components.
- Valve guides and/or valve stem oil seals worn or damaged.
- Piston rings broken, worn or not seated properly.
- Excessive engine coolant and/or oil temperature.
- Excessive engine maintenance intervals. (See Owner's Manual)
- Variation in load cycles.
- Ambient air temperatures.
- Inlet air quality and contamination.

All of these factors and others need to be taken into account and considered to actually determine what "normal" or "excessive" oil consumption is. Typically, more than 2 quarts in 24hrs could be considered excessive on a large cubic inch V-8 engine, after the initial engine break-in period of 150 -200 hours.

### Oil Pressure Diagnosis and Testing

1. With the engine on a level surface, allow adequate drain down time (5-10 minutes) and measure for a low engine oil level.  
Add the recommended grade engine oil, and fill the crankcase until the oil level measures FULL on the oil level indicator.
2. Operate the engine and verify low or no oil pressure on the oil pressure gauge or the oil indicator light.  
Listen for a noisy valve train or a knocking noise.
3. Inspect for the following:
  - Engine oil diluted by moisture or unburned fuel mixtures
  - Improper engine oil viscosity for the expected temperature
  - Incorrect or faulty oil pressure gauge sensor
  - Incorrect or faulty oil pressure gauge
  - Plugged oil filter
  - Malfunctioning oil filter bypass valve

4. Remove the oil pressure gauge sensor or another engine block oil gallery plug.
5. Install an oil pressure gauge.
6. Start the engine and then allow the engine to reach normal operation temperature.
7. Measure the engine oil pressure at the following RPM:

#### Specification

**7.1. 103 kPa (15 PSI) (minimum) at 1,000 RPM**

**7.2. 206 kPa (30 PSI) (minimum) at 2,000 RPM**

**7.3. 275 kPa (40 PSI) (minimum) at 2,800 RPM**

8. If the engine oil pressure is below minimum specifications, inspect the engine for one or more of the following:
  - Oil pump worn or dirty
  - Malfunctioning oil pump pressure relief valve
  - Oil pump screen loose, plugged or damaged
  - Excessive bearing clearance
  - Cracked, porous or restricted oil galleries
  - Engine block oil gallery plugs missing or incorrectly installed
  - Broken valve lifters
  - Oil cooler or cooler lines plugged, restricted or kinked

## Oil Leak Diagnosis

Step	Action	Value(s)	Yes	No
<p><b>Important:</b> You can repair most fluid leaks by first visually locating the leak, repairing or replacing the component, or by resealing the gasket surface. Once the leak is identified, determine the cause of the leak. Repair the cause of the leak as well as the leak itself.</p>				
1	<ol style="list-style-type: none"> <li>1. Operate the engine until it reaches normal operating temperature.</li> <li>2. Place the engine on a level surface, over a large sheet of paper or other clean surface.</li> </ol>	—	Go to Step 2	System OK
2	Can you identify the type of fluid and the approximate location of the leak?	—	Go to Step 10	Go to Step 3
3	<ol style="list-style-type: none"> <li>1. Visually inspect the suspected area. Use a small mirror to assist in looking at hard to see areas.</li> <li>2. Check for leaks at the following locations: <ul style="list-style-type: none"> <li>• Sealing surfaces</li> <li>• Fittings</li> <li>• Cracked or damaged components</li> </ul> </li> </ol> <p>Can you identify the type of fluid and the approximate location of the leak?</p>	—	Go to Step 10	Go to Step 4
4	<ol style="list-style-type: none"> <li>1. Completely clean the entire engine and surrounding components.</li> <li>2. Operate the engine for several hours at normal operating temperature and at varying speeds.</li> <li>3. Park the vehicle on a level surface, over a large sheet of paper or other clean surface.</li> <li>4. Wait (15 minutes).</li> <li>5. Identify the type of fluid and the approximate location of the leak.</li> </ol> <p>Can you identify the type of fluid and the approximate location of the leak?</p>	—	Go to Step 10	Go to Step 5
5	<ol style="list-style-type: none"> <li>1. Visually inspect the suspected area. Use a small mirror to assist in looking at hard to see areas.</li> <li>2. Check for leaks at the following locations: <ul style="list-style-type: none"> <li>• Sealing surfaces</li> <li>• Fittings</li> <li>• Cracked or damaged components</li> </ul> </li> </ol> <p>Can you identify the type of fluid and the approximate location of the leak?</p>	—	Go to Step 10	Go to Step 6
6	<ol style="list-style-type: none"> <li>1. Completely clean the entire engine and surrounding components.</li> <li>2. Apply an aerosol-type powder (baby powder, foot powder, etc.) to the suspected area.</li> <li>3. Operate the engine for several hours at normal operating temperature and at varying speeds.</li> <li>5. Identify the type of fluid and the approximate location of the leak, from the discolorations in the powder surface.</li> </ol>			

7	Can you identify the type of fluid and the approximate location of the leak?	—	Go to Step 10	Go to Step 4
8	<ol style="list-style-type: none"> <li>1. Visually inspect the suspected area. Use a small mirror to assist in looking at hard to see areas.</li> <li>2. Check for leaks at the following locations: <ul style="list-style-type: none"> <li>• Sealing surfaces</li> <li>• Fittings</li> <li>• Cracked or damaged components</li> </ul> </li> </ol> <p>Can you identify the type of fluid and the approximate location of the leak?</p>	—	Go to Step 10	Go to Step 8
9	<p>Use J 28428-E, Dye and Light Kit, in order to identify the type of fluid and the approximate location of the leak. Refer to manufacturer's instructions when using the tool.</p> <p>Can you identify the type of fluid and the approximate location of the leak?</p>	—	Go to Step 10	Go to Step 9
10	<ol style="list-style-type: none"> <li>1. Visually inspect the suspected area. Use a small mirror to assist in looking at hard to see areas.</li> <li>2. Check for leaks at the following locations: <ul style="list-style-type: none"> <li>• Sealing surfaces</li> <li>• Fittings</li> <li>• Cracked or damaged components</li> </ul> </li> </ol> <p>Can you identify the type of fluid and the approximate location of the leak?</p>	—	Go to Step 10	System OK
11	<ol style="list-style-type: none"> <li>1. Inspect the engine for mechanical damage. Special attention should be shown to the following areas: <ul style="list-style-type: none"> <li>• Higher than recommended fluid levels</li> <li>• Higher than recommended fluid pressures</li> <li>• Plugged or malfunctioning fluid filters or pressure bypass valves</li> <li>• Plugged or malfunctioning engine ventilation system</li> <li>• Improperly tightened or damaged fasteners</li> <li>• Cracked or porous components</li> <li>• Improper sealants or gaskets where required</li> <li>• Improper sealant or gasket installation</li> <li>• Damaged or worn gaskets or seals</li> <li>• Damaged or worn sealing surfaces</li> </ul> </li> <li>2. Inspect the engine for customer modifications.</li> </ol> <p>Is there mechanical damage, or customer modifications to the engine?</p>	—	Go to Step 11	System OK
12	Repair or replace all damaged or modified components. Does the engine still leak oil?	—	Go to Step 1	—

## Lubrication Description

The gear-type oil pump is driven through an intermediate shaft. The intermediate shaft is driven by the oil pump drive, which is gear driven by the camshaft. The oil is drawn from the oil pan through a pickup screen and tube, into the oil pump (1). Pressurized oil flows through the oil filter (2), back into the engine (3), and is then distributed to the upper oil galleries (4). Oil must flow around the oil pump drive in order to reach the right side valve lifters properly. The oil is delivered through internal passages in order to lubricate camshaft and crankshaft bearings and to provide lash control in the hydraulic valve lifters. Oil is metered from the valve lifters through the valve push rods in order to lubricate the valve rocker arms and ball pivots. Oil returning to the oil pan from the cylinder heads and the front camshaft bearing, lubricates the camshaft timing chain and the crankshaft and the camshaft sprockets. There is one bypass valve located in the engine block, above the oil filter. If the oil filter becomes plugged, the pressurized oil is diverted around the top of the oil filter by the (Filter By-Pass).

Oil flow without external oil cooler

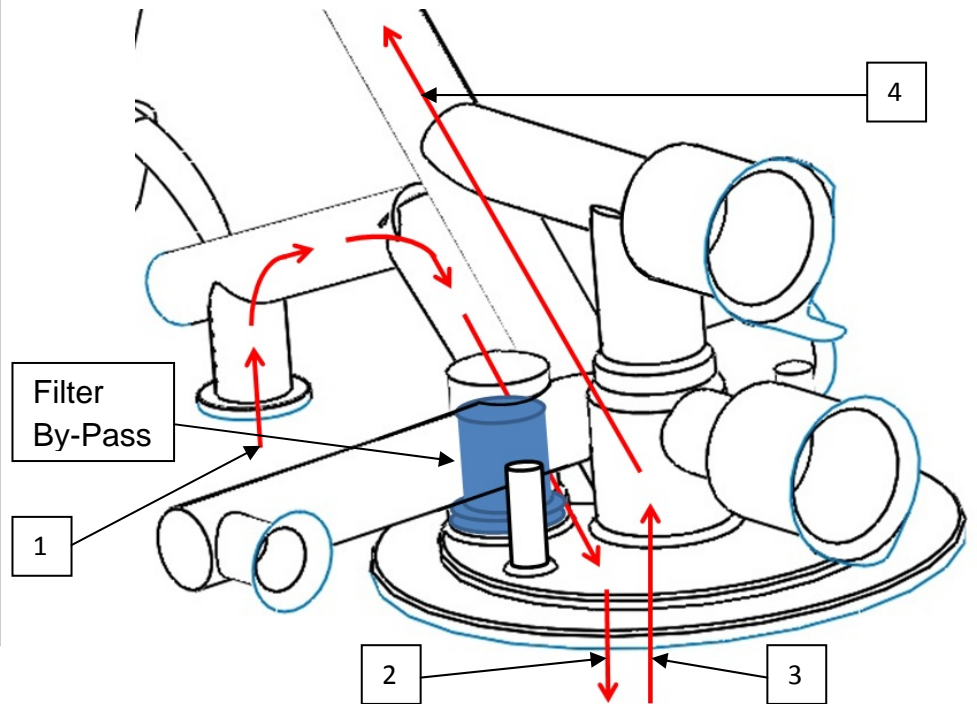

The gear-type oil pump is driven through an intermediate shaft. The intermediate shaft is driven by the oil pump drive, which is gear driven by the camshaft. The oil is drawn from the oil pan through a pickup screen and tube, into the oil pump (1). Pressurized oil flows through the oil filter (2), into the oil cooler (3), out of the oil cooler and is then distributed to the upper oil galleries (4). Oil must flow around the oil pump drive in order to reach the right side valve lifters properly. The oil is delivered through internal passages in order to lubricate camshaft and crankshaft bearings and to provide lash control in the hydraulic valve lifters. Oil is metered from the valve lifters through the valve push rods in order to lubricate the valve rocker arms and ball pivots. Oil returning to the oil pan from the cylinder heads and the front camshaft bearing, lubricates the camshaft timing chain and the crankshaft and the camshaft sprockets. There are two bypass valves located in the engine block, above the oil filter. The oil (Filter By-Pass) valve and the oil (Cooler By-Pass) valve. If the oil filter becomes plugged, the pressurized oil is diverted around the top of the oil filter. The oil (Filter By-Pass) valve is forced open, allowing the oil to continue on to the oil cooler and engine oil passages. If the oil cooler flow becomes blocked, either from a plugged oil cooler or blocked or kinked oil cooler line, the oil (Cooler By-Pass) valve is forced open, allowing oil to flow directly into the engine oil passages. Oil does not flow into or out of the engine oil cooler.

Oil flow with external oil cooler

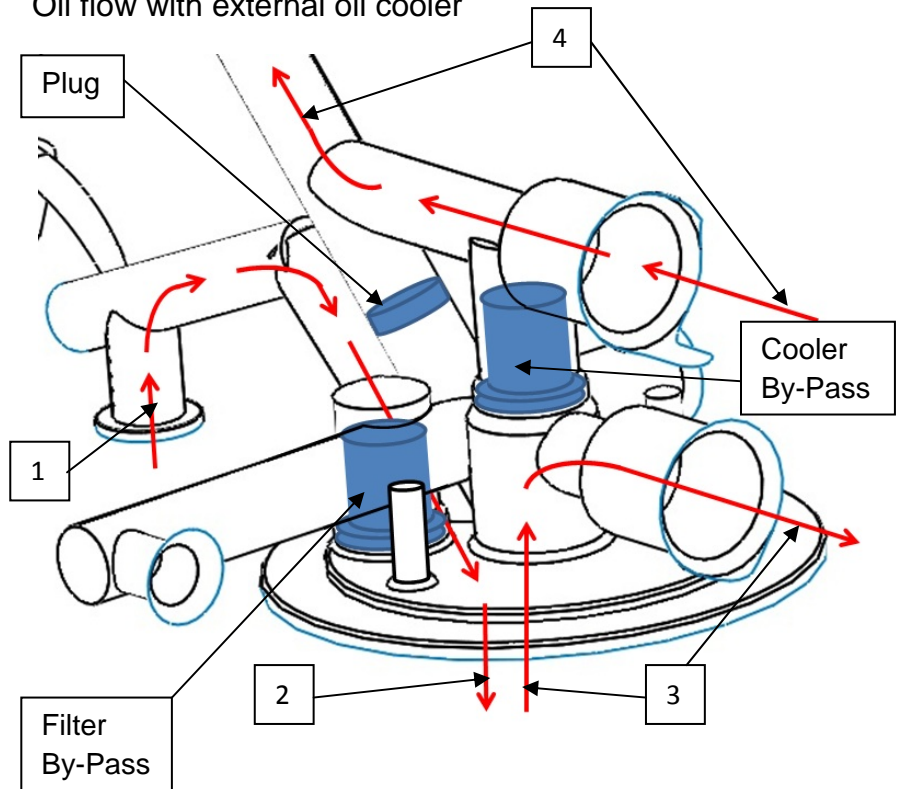

---

## Separating Parts

**Important:** Many internal engine components will develop specific wear patterns on their friction surfaces.

When disassembling the engine, internal components **MUST** be separated, marked or organized in a way to ensure reinstallation to the original location and position.

Separate, mark or organize the following components:

- Piston to the specific cylinder bore
- Piston rings to the piston
- Connecting rod to crankshaft journal
- Connecting rod to the bearing cap
- Crankshaft and connecting rod bearings
- Camshaft and valve lifters
- Valve lifters, guides, pushrods pivot supports and rocker arms
- Valve to the valve guide
- Valve spring and shim to the cylinder head location
- Engine block crankshaft bearing cap location and direction
- Oil pump drive and driven gears

## Cleanliness and Care

- Throughout this section, it should be understood that proper cleaning and protection of machined surfaces and friction areas is part of the repair procedure.  
This is considered standard shop practice even if not specifically stated.
- When any internal engine parts are serviced, care and cleanliness is important.
- When components are removed for service, they should be marked, organized or retained in a specific order for reassembly.
- At the time of installation, components should be installed in the same location and with the same mating surface as when removed.
- An engine is a combination of many machined, honed, polished and lapped surfaces with tolerances that are measured in millimeters or thousandths of an inch. These surfaces should be covered or protected to avoid component damage.
- A liberal coating of clean engine oil should be applied to friction areas during assembly.
- Proper lubrication will protect and lubricate friction surfaces during initial operation.

## Replacing Engine Gaskets

### Gasket Reuse and Applying Sealant

- Do not reuse any gasket unless specified.
- Gaskets that can be reused will be identified in the service procedure.
- Do not apply sealant to any gasket or sealing surface unless specified in the service procedure.

### Separating Components

- Use a rubber mallet in order to separate the components.
- Bump the part sideways in order to loosen the components.
- Bumping of the component should be done at bends or reinforced areas of the component to prevent distortion of the components.

### Cleaning Gasket Surfaces

- Use care to avoid gouging or scraping the sealing surfaces.
- Use a plastic or wood scraper in order to remove all the sealant from the components.  
Do not use any other method or technique to remove the sealant or the gasket material from a part.
- Do not use abrasive pads, sand paper or power tools to clean the gasket surfaces.
  - These methods of cleaning can cause damage to the component sealing surfaces.
  - Abrasive pads also produce a fine grit that the oil filter cannot remove from the engine oil.  
This fine grit is abrasive and can cause internal engine damage.

---

## Assembling Components

- Assemble components using only the sealant (or equivalent) that is specified in the service procedure.
- Sealing surfaces must be clean and free of debris or oil.
- Specific components such as crankshaft oil seals or valve stem oil seals may require lubrication during assembly.
- Components requiring lubrication will be identified in the service procedure.
- Apply only the amount of sealant specified in the service procedure to a component.
- Do not allow the sealant to enter into any blind threaded holes, as the sealant may prevent the fastener from clamping properly or cause component damage when tightened.
- Tighten fasteners to the proper specifications. DO NOT over tighten the fasteners.

## Use of RTV and Anaerobic Sealer

### Sealant Types

**Important:** The correct sealant and amount of sealant must be used in the proper location to prevent oil leaks, coolant leaks or the loosening of the fasteners. DO NOT interchange the sealants. Use only the sealant (or equivalent) as specified in the service procedure.

The following 2 major types of sealant are commonly used in engines:

- Aerobic sealant (Room Temperature Vulcanizing (RTV))
- Anaerobic sealant, which include the following:
  - Gasket eliminator
  - Pipe
  - Threadlock

### Aerobic Type Room Temperature Vulcanizing (RTV) Sealant

Aerobic type Room Temperature Vulcanizing (RTV) sealant cures when exposed to air. This type of sealant is used where 2 components (such as the intake manifold and the engine block) are assembled together.

Use the following information when using RTV sealant:

- Do not use RTV sealant in areas where extreme temperatures are expected. These areas include:
  - The exhaust manifold
  - The head gasket
  - Any other surfaces where a different type of sealant is specified in the service procedure.
- Always follow all the safety recommendations and the directions that are on the RTV sealant container.
- Use a plastic or wood scraper in order to remove all the RTV sealant from the components.

**Important:** Do not allow the RTV sealant to enter any blind threaded holes, as it may prevent the fasteners from clamping properly or cause damage when the fastener is tightened.

- The surfaces to be sealed must be clean and dry.
- Use a RTV sealant bead size as specified in the service procedure.
- Apply the RTV sealant bead to the inside of any bolt holes areas.
- Assemble the components while the RTV sealant is still wet to the touch (within 3 minutes). Do not wait for the RTV sealant to skin over.
- Tighten the fasteners in sequence (if specified) and the proper torque specifications. DO NOT over tighten the fasteners.

### Anaerobic Type Gasket Eliminator Sealant

Anaerobic type gasket eliminator sealant cures in the absence of air. This type of sealant is used where 2 rigid parts (such as castings) are assembled together. When 2 rigid parts are disassembled and no sealant or gasket is readily noticeable, then the 2 parts were probably assembled using an anaerobic type gasket eliminator sealant.

Use the following information when using gasket eliminator sealant:

- Always follow all the safety recommendations and directions that are on the gasket eliminator sealant container.
- Apply a continuous bead of gasket eliminator sealant to one flange.

The surfaces to be sealed must be clean and dry.

**Important:** Do not allow the gasket eliminator sealant to enter any blind threaded holes, as the gasket eliminator sealant may prevent the fasteners from clamping properly, seating properly or cause damage when the fastener is tightened.

- Apply the gasket eliminator sealant evenly to get a uniform thickness of the gasket eliminator sealant on the sealing surface.

---

**Important:** Gasket eliminator sealed joint fasteners that are partially torqued and the gasket eliminator sealant allowed to cure more than five minutes, may result in incorrect shimming and sealing of the joint.

- Tighten the fasteners in sequence (if specified) and to the proper torque specifications. DO NOT over tighten the fasteners.
- After properly tightening the fasteners, remove the excess gasket eliminator sealant from the outside of the joint.

### **Anaerobic Type Threadlock Sealant**

Anaerobic type threadlock sealant cures in the absence of air. This type of sealant is used for thread locking and sealing of bolts, fittings, nuts and studs. This type of sealant cures only when confined between 2 close fitting metal surfaces.

- Always follow all safety recommendations and directions that are on the threadlock sealant container.
- The threaded surfaces to be sealed must be clean and dry.
- Apply the threadlock sealant as specified on the threadlock sealant container.

**Important:** Fasteners that are partially torqued and then the threadlock sealant allowed to cure more than five minutes may result in incorrect clamp load of assembled components.

- Tighten fasteners in sequence (if specified) and to the proper torque specifications. DO NOT over tighten the fasteners.

### **Anaerobic Type Pipe Sealant**

Anaerobic type pipe sealant cures in the absence of air and remains pliable when cured. This type of sealant is used where 2 parts are assembled together and require a leak proof joint.

Use the following information when using pipe sealant:

- Do not use pipe sealant in areas where extreme temperatures are expected. These areas include:
  - The exhaust manifold
  - The head gasket
  - Surfaces where a different sealant is specified
- Always follow all the safety recommendations and the directions that are on the pipe sealant container.
- The surfaces to be sealed must be clean and dry.
- Use a pipe sealant bead of the size or quantity as specified in the service procedure.

**Important:** Do not allow the pipe sealant to enter any blind threaded holes, as the pipe sealant may prevent the fasteners from clamping properly, seating properly or cause damage when the fastener is tightened.

- Apply the pipe sealant bead to the inside of any bolt hole areas.
- Apply a continuous bead of pipe sealant to 1 sealing surface.
- Tighten the fasteners in sequence (if specified) and to the proper torque specifications. DO NOT over tighten the fasteners

### **Tools and Equipment**

- Special tools are listed and illustrated throughout this section with a complete listing at the end of the section. These tools (or their equivalents) are specially designed to quickly and safely accomplish the operations for which they are intended. The use of these special tools will also minimize possible damage to engine components. Some precision measuring tools are required for inspection of certain critical components. Torque wrenches are necessary for the proper tightening of various fasteners.
- To properly service the engine assembly, the following items should be readily available:
  - Approved eye protection and safety gloves
  - A clean, well-lit work area
  - A suitable parts cleaning tank
  - A compressed air supply
  - Trays or storage containers to keep parts and fasteners organized
  - An adequate set of hand tools
  - Approved engine repair stand
  - An approved engine lifting device that will adequately support the weight of the component