

Your Complete Power-Pack Solutions Specialists

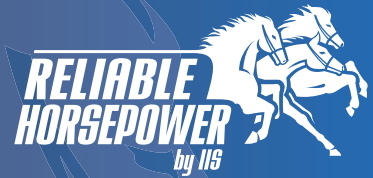

6.2L | ENGINE

Excellent Performance and Durability

Over 60 years of industrial engine experience allows IIS to deliver specifically engineered, sophisticated, and durable engine packages that are tailored to your specific needs.



Power Generation Output Rankings

Complete Power-Pack: **1800rpm, kWm**
Radiator through Housing

Fuel	Standby	Prime
LPG	78	68
Nat. Gas	70	64

- EPA certified for use on pipeline natural gas, propane, and wellhead gas
- 700-1800 BTU wellhead gas capable/certified
- All ratings at sea-level, 77°F ambient
- All ratings will be effected by altitude and ambient temperature

Reliable HP Industrial Engines Mean Uncompromised Power:

- High-flow cylinder head with straighter intake ports and a higher compression ratio delivers impressive horsepower
- Roller valve lifters for reduced friction and improved performance
- Designed for heavy-duty, industrial use
- Modular design for consistency
- Engineered for reliability and long life cycles
- Cast and machined in North America

6.2L

ENGINE SPECIFICATIONS

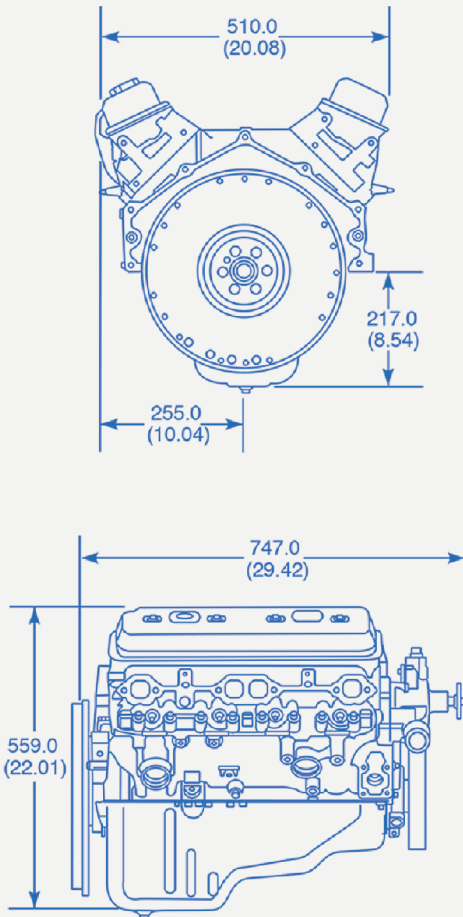

Type	6.2L V-8
Displacement	383 cid
Engine Orientation	Longitudinal
Compression Ratio	9.4:1
Valve Configuration	Overhead valves
Bore & Stroke	101.60 mm x 95.25 mm
Main Bearing Caps	4 Bolt Main
Rear Main Seal	1 Piece
Intake Manifold	Dual Plane
Oil Pan Capacity	5 qt
Engine Rotation	Counter-Clockwise

Horsepower (Peak)

Propane	181 hp @ 3000 rpm
Natural Gas	169 hp @ 3000 rpm

Torque

Propane	462 lb-ft @ 1600 rpm
Natural Gas	433 lb-ft @ 1600 rpm

Reliable HP Engines Use the Following Heavy Duty Materials

Block	Cast Iron	Connecting Rods	Forged Steel
Cylinder Heads	Cast Iron	Exhaust Seat	Inserts
Intake Manifold	Aluminum	Intake Seat	Induction Hardened
Crankshaft	Nodular Iron		
Camshaft	5150 Steel Billet		